



BROWNS

EST: 1830

Agricultural Machinery Co. Ltd

Manufacturers of Farm Implements & Machinery



Ex1 Post Hammer

For 1 to 3 Tonne Excavators

Owners Illustrated Instruction Book & Parts List

Grovebury Road, Leighton Buzzard, Bedfordshire. LU7 4UX. UK.

Tel:01525 375157. Fax:01525 385222.

Email: enquires@brownsagricultural.co.uk

www.brownsagricultural.co.uk

Contents

EC declaration of conformity	1
Machine Identification	1
1.0 Introduction	2
1.1 General Information	2
2.0 Technical Specifications	3
3.0 Safe Use	4
4.0 Safety notes and warnings	5
4.1 Machine Decals	6
5.0 Intended Use	7
5.1 Operating Instructions	7
6.0 Storage	8
7.0 Tightening torques & spanner sizes	8
8.0 Maintenance instructions	9
9.0 Parts Lists	10
10.0 Rock Spike Attachment	15
11.0 Dismantling & disposal	16
12.0 Warranty Guidelines	16
12.1 Modifications	16

EC Declaration of Conformity

Browns Agricultural Machinery Co Ltd declare that the **Browns Ex1 Post Hammer**, as defined by the Serial Number attached to the machine, conforms with the following Directives and Regulations, and has been certified accordingly.

EC Machinery Directive 2006/42/EC.
The Supply of Machinery (Safety) Regulations 2008.
The Provision and Use of Work Equipment Regulations 1998.

Specifically related harmonised standards are:

EN ISO 12100-1: 2003 (Safety of Machinery).
EN ISO 12100-2: 2003 (Safety of Machinery).
EN ISO 4254-1 : 2005 (Agricultural machinery - Safety).

THE MANUFACTURER:

Browns Agricultural Machinery Co. Ltd.
Grovebury Road,
Leighton Buzzard,
Bedfordshire. LU7 4UX.

Telephone (+44) 0 1525 375157

Person empowered to draw up the declaration on behalf of the manufacturer of his authorized representative

Name: David Hanson

Signature:



Job Title: Design & Safety

Employer: Browns Agricultural Machinery

Place of declaration: LU7 4UX

Date of declaration: 1st December 2016

Machine Identification

Enter the relevant data in the following list upon acceptance of the machine.

Serial Number	
Type of Machine	
Machine Width	
Year of Construction	
Delivery Date	
First Operation	
Dealer Name	
Dealer Address	

1.0 Introduction

Congratulations on your purchase of a new Browns machine. In order to correctly use the machine please carefully read this manual. The manual has been written to provide operating and maintenance procedures and related safety information which will allow you to use and maintain this machine in a correct and safe manner.

This operators manual should be regarded as part of the machine. You must ensure that you and anyone else who is operating, maintaining or working with the machine be familiar with the operating and maintenance procedures and related safety information contained in this manual.

Owners must give operating instructions to operators or employees before allowing them to operate this machine. It is the operators responsibility to read and understand all safety and operating instructions in this manual. Remember all accidents can be avoided.

A person who has not read and understood all operating and safety instructions is not qualified to operate the machine. An untrained operator exposes themselves and bystanders to possible serious injury or death.



Caution

This symbol indicates important safety messages in this manual. When you see this symbol, be alert to the possibility of injury to yourself or others, and carefully read the message that follows.

**The most important safety device on the machine is a
safe operator**

1.1 General Information

The illustrations and data used in this manual were current at the time of printing, but due to possible engineering or production changes, this product may vary slightly in detail. Browns reserves the right to redesign or change components as may be necessary without notification to anyone.

No liability can be accepted for inaccuracies or omissions in this manual, although every possible care has been taken to make it as complete and accurate as possible.

Throughout this manual, references may be made to,

- **LEFT-HAND SIDE** - the side which is on the left only when an observer is facing in the normal forward direction of travel of the machine, i.e. the operator looking forward from rear of machine.
- **RIGHT-HAND SIDE** - the side which is on the right only when an observer is facing in the normal forward direction of travel of the machine.
- **COMPETENT PERSON** - for any task means a person who has acquired through training, qualifications or experience, or a combination of them, the knowledge and skills to carry out that task.

2.0 Technical Specifications

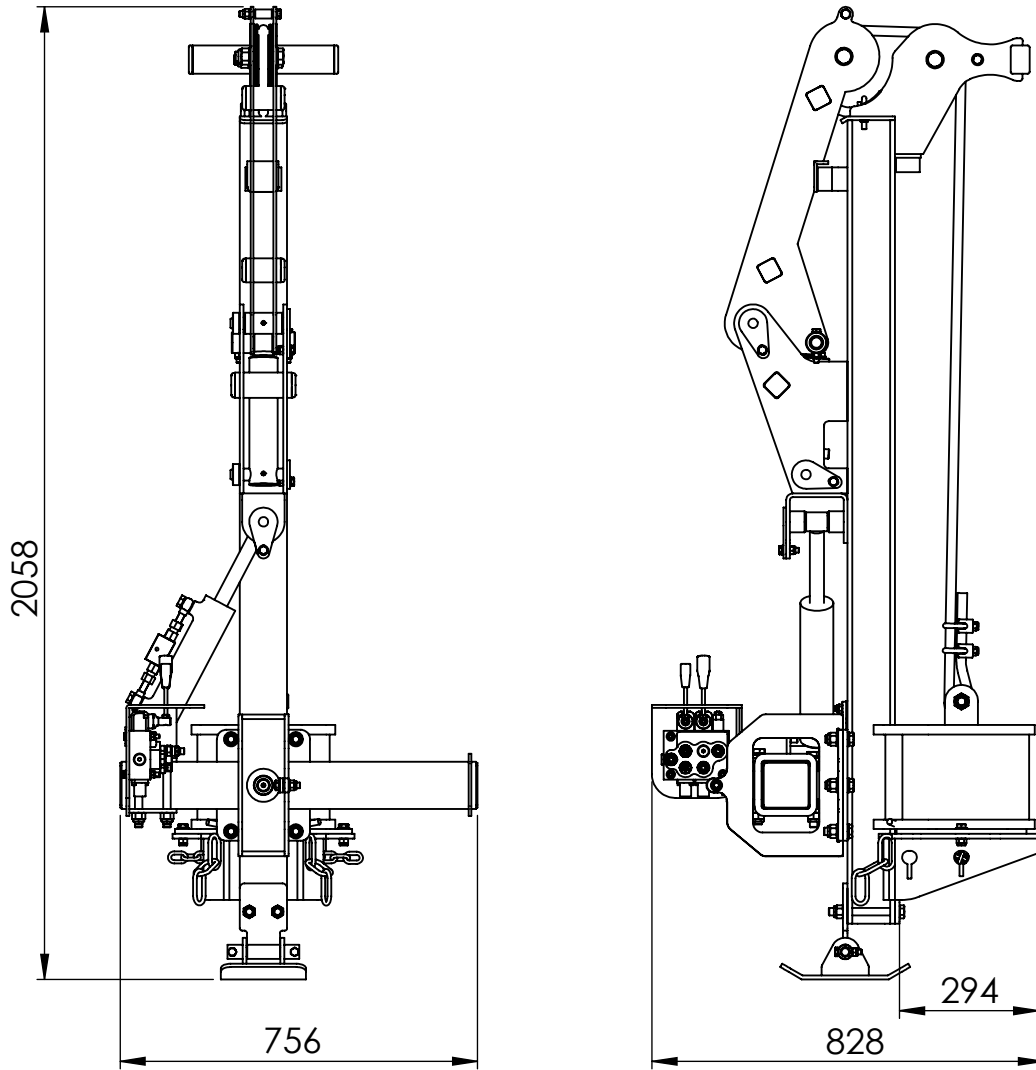

SPECIFICATIONS	
HEIGHT	2058 mm
WIDTH	756 mm
DEPTH	828 mm
WEIGHT	250 kg
HAMMER WEIGHT	120 kg
LEG LENGTH	900 mm
ROCK SPIKE DIAMETER	80 mm
ROCK SPIKE LENGTH	900 mm
Max POST WIDTH	230 mm
Max OIL PRESSURE	300 bar
Side Tilt	25 deg.

3.0 Safe Use

The owner must provide safety instructions to all persons involved in using the post hammer. The safety instructions must be kept with the post hammer in the receptacle provided for that purpose.

The owner must ensure that persons operating the post hammer, and those otherwise involved in its operation, are competent to do so. All persons involved in the operation of the post hammer must be instructed in the safety instructions.

Prior to use, the post driver should be inspected to ensure it is functioning correctly, including all its safety features, such as guards. If any safety feature is not functioning correctly, the post hammer must not be used.

The area where the post hammer is to operate must be assessed for hazards that may affect the operation, including the location of overhead power lines and underground services, and the terrain where the post hammer will be used.

The operator or other persons must not support and guide the post during the driving operation, a post cap is designed for that role.

The post hammer must remain stable during travel and use and must not exceed the excavator manufacturers specifications. The excavator to which the post hammer is attached must have sufficient lifting capacity to safely handle the post hammer, both for transportation and operation.

The owner must provide appropriate PPE to persons involved in the post driving operation. Hearing and eye protection must be provided.

When the post driver is not being used, it must be immobilised. The excavator must be switched off and the key removed. When the post driver is immobilised, the hammer must be placed in its lowest position.

When the post hammer is being transported while attached to the excavator :

- It should be correctly secured to the boom
- Along a public road, all road regulations, including height restrictions, must be observed.
- The hammer should be in its lowest position.
- Across a farm or other work site, an assessment of the terrain should be made. Particular care is required to avoid contact with overhead power lines and when travelling on slopes or uneven ground. Travel at reduced speed.

4.0 Safety Notes & Warnings



Only competent and trained operators should use and maintain the machine. Ensure this manual has been read by every person who is intending to use or maintain it.



Be aware of moving parts on the machine that may cause a crushing hazard to the hands and body.



Study operator manual thoroughly before maintenance is carried out and always turn the tractor off and remove key.



Ensure that the excavator is of sufficient size to provide adequate stability when in operation, refer to the tractors operator manual when operating on sloping ground.



High pressure fluid hazard. Escaping oil under pressure can penetrate the skin causing serious injury. Avoid the hazard by relieving pressure before disconnecting hydraulic pipes. Search for leaks with a piece of cardboard.



Do not allow any person to stand in between the machine and the excavator unless the machine is lowered to the ground and the tractor is turned off with the key removed.



Do not allow any person to stand within 5 meters of the work area where the post is being driven. Do not continue operation if a solid obstruction has been hit that has stopped the travel of the post.

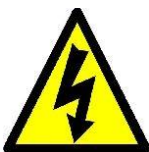

Beware of overhead electrical hazards and underground services. Contact local service providers if unsure of underground cables or pipes.



While hammering post fragments or dust particles may be ejected. Suitable eye protection must be worn (safety glasses complying with EN166).



The falling hammer striking the post cap and post may cause the noise level to exceed 85db and the operators must wear suitable ear protection (complying with EN352).



Wearing well fitting and suitable protective gloves may prevent unnecessary injury to hands and fingers .

4.1 Machine Decals

The decals should be considered part of the machine. Any decal that refers to warnings or hazards must be replaced immediately if it become lost or illegible.



Part No. 80010



Part No. 80073



Part No. 80047



Part No. 80006

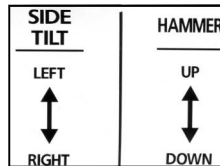

Part No. 80074



Part No. 80002



Serial number required
Before a duplicate can
Be issued.



Part No. 80076

4.2 Delivery

The machine is delivered fully assembled. Only a competent driver should attempt to unload the machine with knowledge of slinging and lifting. A forklift or loader with sufficient lifting capacity should be used, check the technical specifications for the specific model to find the machine weight before any lifting takes place. Place the machine onto a firm flat surface.

Once unloaded check over the machine for any transport damage to hydraulic hoses or the frame.

5.0 Intended use

The Browns Ex1 Post hammer is intended to be mounted on an excavator that is rated between 1 and tonnes, to give safe stability. The post hammer is hydraulically driven by the excavator. The excavator must supply a constant free flowing hydraulic flow through the post hammers valve block while in operation. If it is not free flowing then the hammer will not fall at the correct speed to drive posts.

5.1 Operating instructions

Once you have read and understood the Safe Use chapter (page 4) you are now ready to use the post hammer. Connect the hammer to the excavator with the two pins provided and lock the pins in position. Connect the hydraulic couplers ensuring the excavator is turned off. Crowd the post hammer back and proceed to the required area of work.

Position the post hammer where the post is to be driven and extend the leg to set the height you require in relation to the post height to be obtained. Attach the post cap to the hammer using the post cap chains and raise the hammer and cap so a post can be placed underneath. Slowly lower the hammer and cap onto the top of the post and release the chains. There is a spike under the post cap that will stop the post slipping and a clamping chain to attach around the cap and post to hold it firm.



NEVER PLACE HANDS NEAR THE POST OR HAMMER WHEN OPERATING AS THIS MAY RESULT IN CRUSHING OR FINGER AMPUTATIONS.

Check the post is vertical and adjust with the boom and hammer controls. Start driving the post by raising the hammer 200mm to give initial drive and then increase driving height once started. If the post starts to go off vertical or away from the centre of the hammer, stop immediately and reset the vertical.



If the post hits an obstacle, starts to crack or the post top starts to spread, STOP IMMEDIATELY. If it has hit an obstacle the a pilot hole may be required.

If the post stops and driving continues it can result in the post breaking and splintered wood being ejected at speed. This can result in injuries to the body and eyes.

Once the post has reached the required depth the post cap is attached to the hammer which is raised off the post. Move the excavator to the next post to be driven.

6.0 Storage

- Store the unit undercover if possible.
- The post hammer is designed to rest horizontally on the post cap & fixed stand
- Thoroughly clean and grease the unit before storage to ensure it is in full operating condition when next required.
- Protect and exposed areas against rust. If you need to spray areas with oil, use light biologically degradable oils such as rape oil.
- Store the unit in an area away from human activity.
- Do not park equipment where it will be exposed to livestock. Damage and livestock injury could result.
- Do not allow children to play on or around the stored unit.
- Make sure all parked machines are on a hard, level surface and engage all safety devices, parking stands or stay bars if provided.
- If blocking is used, make sure it is solid and secure before leaving area.

7.0 Tightening torques and spanner sizes

Size	Grade 8.8				Grade 10.9				Grade 12.9				Spanner Sizes mm
	lubricated		dry (2)		lubricated		dry (2)		lubricated		dry (2)		
	Nm	lb-ft	Nm	lb-ft	Nm	lb-ft	Nm	lb-ft	Nm	lb-ft	Nm	lb-ft	
M6	9	6.5	11	8.5	13	9.5	17	12	15	11.5	19	14.5	10
M8	22	16	28	20	32	24	40	30	37	28	47	35	13
M10	43	32	55	40	63	47	80	60	75	55	95	70	17
M12	75	55	95	70	110	80	140	105	130	95	165	120	19
M14	120	88	150	110	175	130	225	165	205	150	260	190	22
M16	190	140	240	175	275	200	350	255	320	240	400	300	24
M18	260	195	330	250	375	275	475	350	440	325	560	410	27
M20	375	275	475	350	530	400	675	500	625	460	800	580	30
M24	650	475	825	600	925	675	1150	850	1075	850	1350	1000	36
M30	1300	950	1650	1200	1850	1350	2300	1700	2150	1600	2700	2000	46

- (1) "lubricated" means that the screws are treated with a lubricant such as engine oil, or that phosphated or oiled screws are used.
- (2) "dry" means that normal or galvanized screws without any lubrication are used.

The tightening torques listed above are for reference values. They apply provided that operating instructions do not specify other tightening torques for certain screws or nuts.

8.0 Maintenance Instructions

The post hammer must be inspected regularly to ensure it is functioning correctly. All problems identified must be rectified prior to its use. All safety features must be maintained to ensure they are functioning as intended. Where parts or components require replacing, replacements must be identical or equivalent to the original parts or components. All work must be carried out by a competent person.

Before Use

- Check condition of rope, replace if worn / damaged.
- Check rope clamps are tight.
- Check all bolts and nuts are tight.
- Check all hydraulic hoses for damage, replace if required.
- Check all hydraulic connections are tight.
- Grease the slider.

Grease the slider every 10 hours of operation or when it becomes dry. Before storing the post hammer after use check the above list again so the machine is left in a fully function state.

Rope Replacement

If the rope needs replacing the post hammer first needs to be in a horizontal position resting on firm level ground on its stands. Remove the rope clamp connected to the top of the main beam. Remove the bolt in the hammer to release the damaged rope and remove the rope clamps. Thread the rope through the top pulley and fasten one end of the rope to the top of the main beam using the rope clamp. Place the rope round the fixed pulley and down to the hammer. Replace the bolt in the hammer and loop the rope around it. Loosely fit the two rope clamps. Lever the hammer up the slider 100mm, this will take up the initial stretch of the new rope. Pull the rope tight and fasten the rope clamps. Wrap the cut ends of the rope with tape to stop fraying.

9.0 Spare Parts List

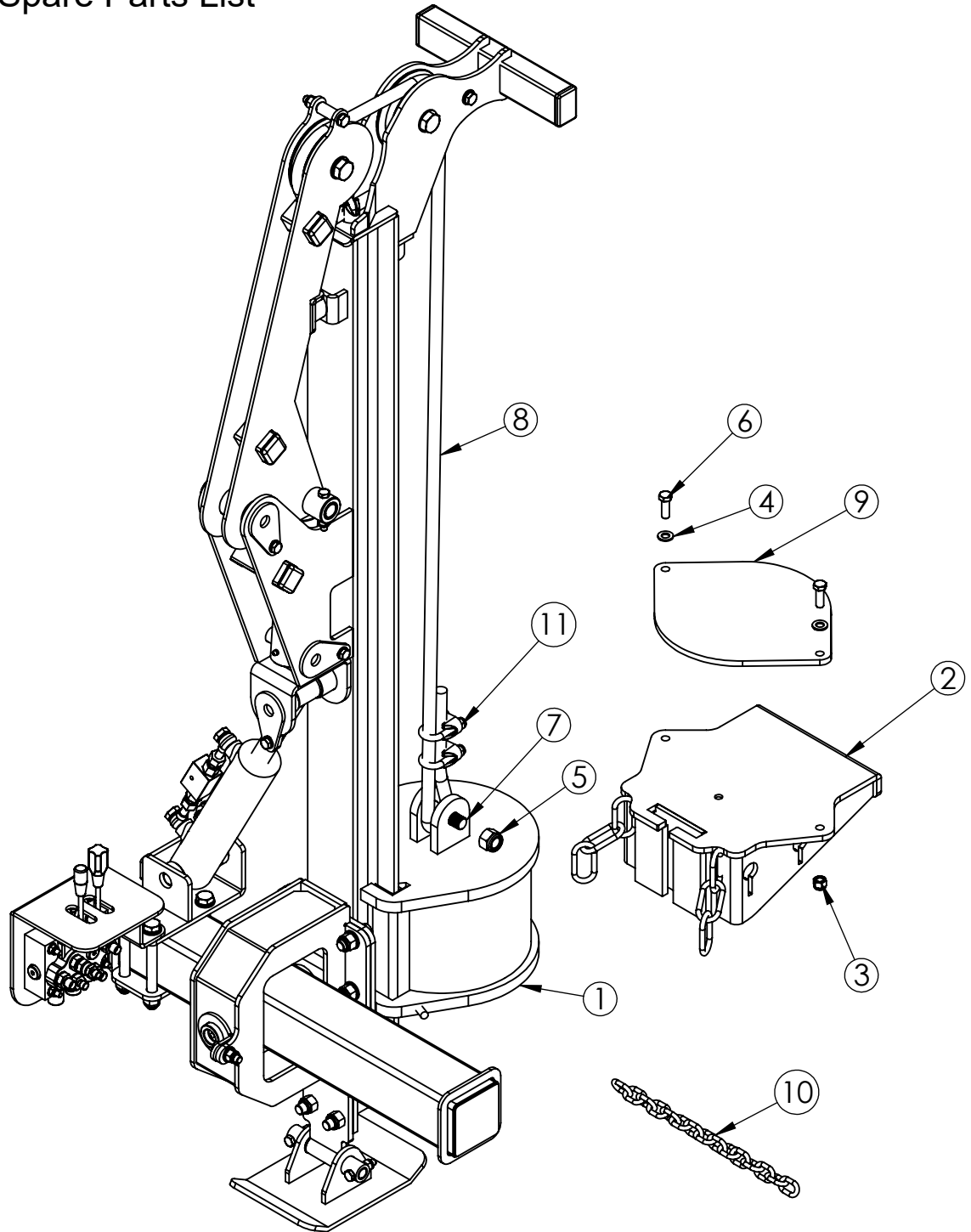

HAMMER ASSEMBLY			
ITEM	PART No	DESCRIPTION	QTY
1	55072	HAMMER	1
2	55078	POST CAP	1
3	70012	M12 NYLOCK NUT	2
4	70136	M12 WASHER	2
5	70412	M20 NYLOCK NUT	1
6	70440	M12 (8.8) x 35 SETSCREW	2
7	71252	M20 (8.8) x 80 BOLT	1
8	71879	ROPE (2.4m)	1
9	71887	RUBBER POST CAP	1
10	71894	POST CLAMP CHAIN	1
11	71933	WIRE ROPE GRIP	2

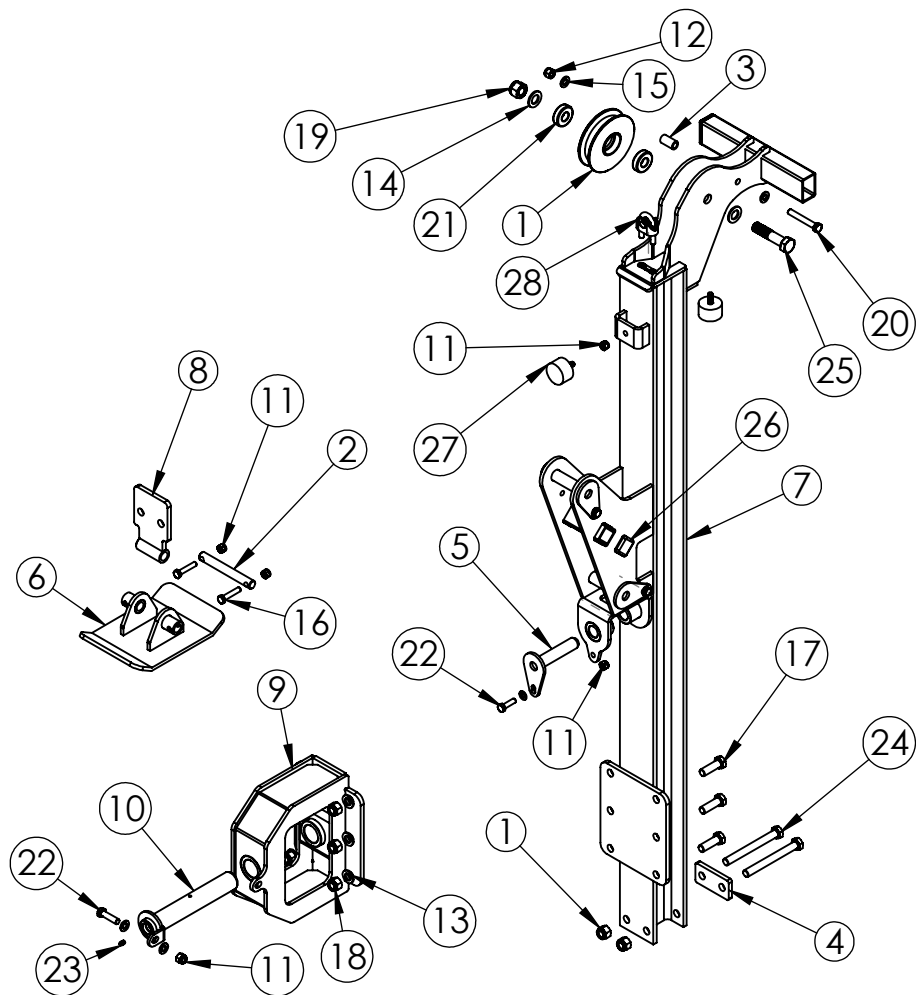

MAST ASSEMBLY			
ITEM	PART No	DESCRIPTION	QTY
1	17051	PULLEY 150	1
2	17139	MAST FOOT PIN	1
3	17163	ROPE GUIDE	1
4	17866	MAST STOP	1
5	53303	SWING PIN	3
6	53312	FOOT	1
7	55069	Ex1 MAST	1
8	55073	FOOT BRACKET	1
9	55074	PIVOT BOX	1
10	55079	Ex1 PIVOT PIN	1
11	70011	M10 NYLOCK NUT	10
12	70012	M12 NYLOCK NUT	1
13	70069	M16 WASHER	6
14	70073	M20 WASHER	2
15	70136	M12 WASHER	2
16	70145	M10 (8.8) x 65 BOLT	2
17	70150	M16 (8.8) x 50 BOLT	6
18	70342	M16 NYLOCK NUT	6
19	70412	M20 NYLOCK NUT	1
20	70437	M12 (8.8) x 90 BOLT	1
21	70666	BEARING 6204ZZ	2
22	70911	M10 (8.8) x 35 BOLT	4
23	71055	GREASE NIPPLE M6 x 1	1
24	71230	M16 (8.8) x 160 BOLT	2
25	71252	M20 (8.8) x 90 BOLT	1
26	71622	PLASTIC CAP 40 x 40	2
27	71741	RUBBER BUFFER	2
28	71933	WIRE ROPE GRIP	1

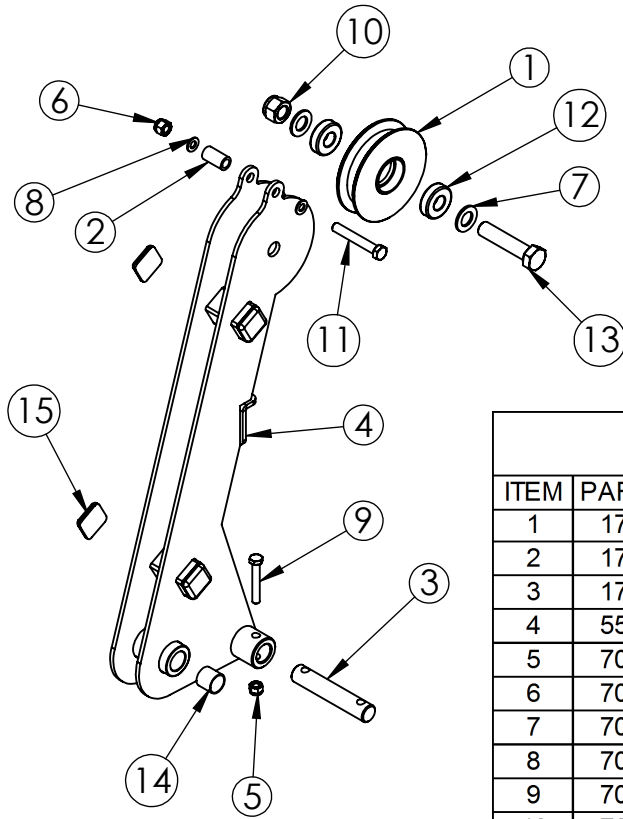

Ex1 PENDULUM			
ITEM	PART No	DESCRIPTION	QTY
1	17051	PULLEY 150	1
2	17163	ROPE GUIDE	1
3	17883	PENDULUM PIN	1
4	55071	Ex1 PENDULUM	1
5	70011	M10 NYLOCK NUT	2
6	70012	M12 NYLOCK NUT	1
7	70073	M20 WASHER	2
8	70136	M12 WASHER	2
9	70145	M10 (8.8) x 65 BOLT	2
10	70412	M20 NYLOCK NUT	1
11	70437	M12 (8.8) x 90 BOLT	1
12	70666	BEARING 6204	2
13	71252	M20 (8.8) x 90 BOLT	1
14	71744	BUSH MB2525	2
15	71622	PLASTIC CAP 40 x 40	4

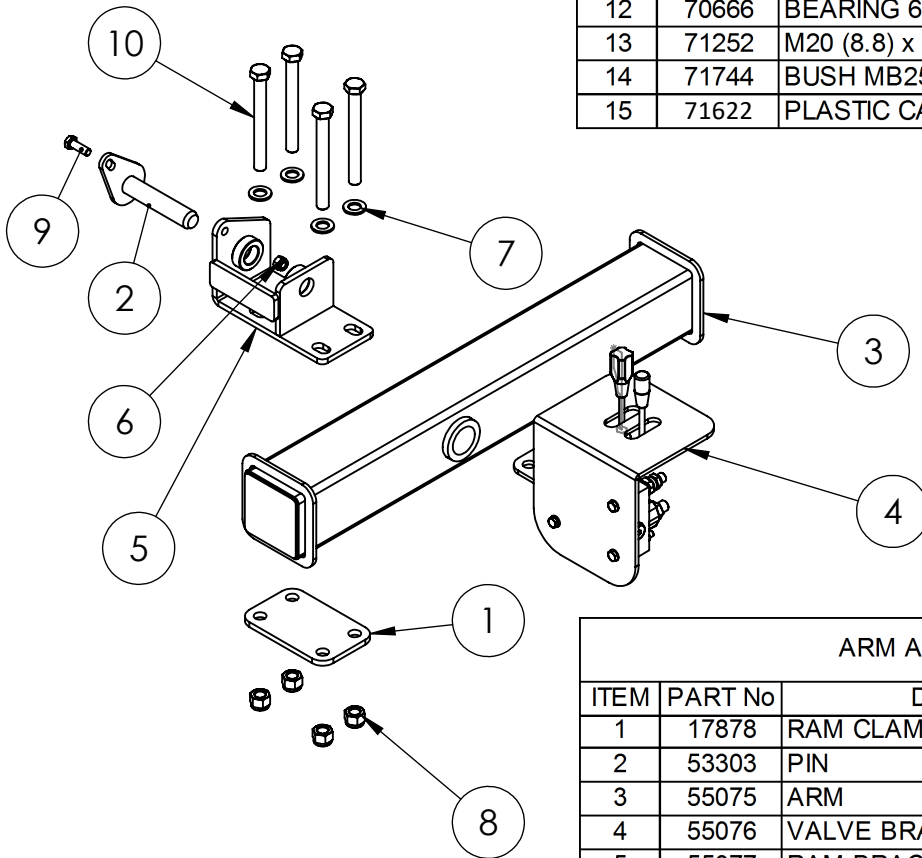

ARM ASSEMBLY			
ITEM	PART No	DESCRIPTION	QTY
1	17878	RAM CLAMP PLATE	1
2	53303	PIN	1
3	55075	ARM	1
4	55076	VALVE BRACKET	1
5	55077	RAM BRACKET	1
6	70011	M10 NYLOCK NUT	1
7	70069	M16 WASHER	8
8	70342	M16 NYLOCK NUT	4
9	70911	M10 (8.8) x 35 SETSCREW	1
10	71230	M16 (8.8) x 160 BOLT	4

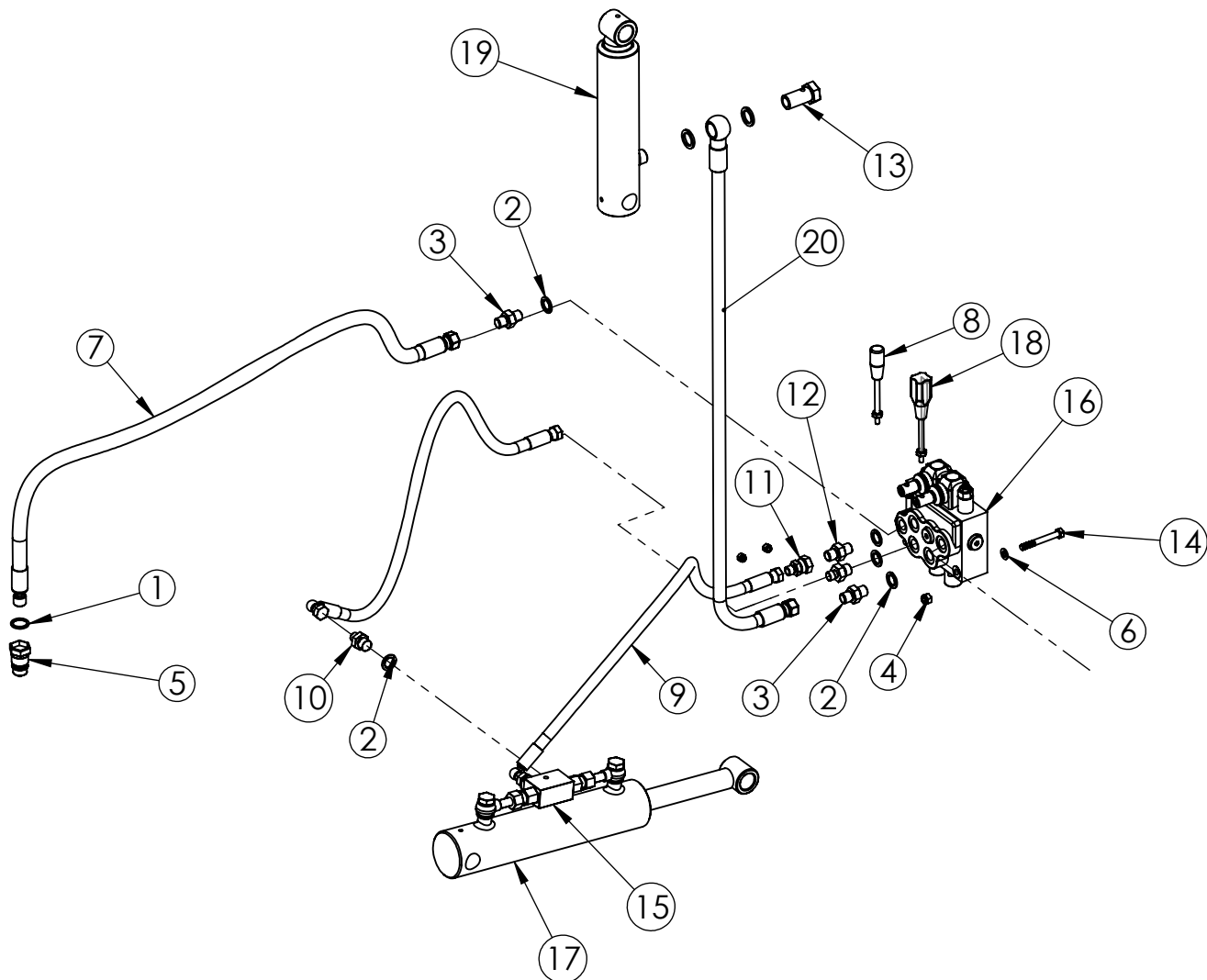

HYDRAULICS ASSEMBLY			
ITEM	PART No	DESCRIPTION	QTY
1	70121	DOWRY SEAL 1/2 BSP	2
2	70122	DOWTY SEAL 3/8 BSP	8
3	70124	ADAPTER 3/8m x 3/8m BSP	3
4	70238	M8 NYLOCK NUT	3
5	70364	Q/R PROBE 1/2 BSP	2
6	70438	M8 WASHER	3
7	71361	3/8 HOSE 2m (1/2m x 3/8f 90ss)	2
8	71633	LEVER	1
9	71781	1/4 HOSE 0.86m (1/4fx1/4f 90CMP)	2
10	71786	ADAPTER 1/4m x 3/8m BSP	2
11	71787	ADAPTER 1/4Mm x 3/8f SWIVEL	1
12	71859	RESTRICTOR 3/8m x 3/8m BSP	1
13	71890	BANJO BOLT 3/8 BSP	1
14	71891	M8 (8.8) x 110 BOLT	3
15	71895	CHECK VALVE c/w PIPES	1
16	71898	VALVE 1xDA 1xSA 3/8 BSP	1
17	71943	RAM 703/2	1
18	72003	LEVER RED	1
19	72023	DISPLACEMENT RAM	1
20	72024	HOSE 1/2 x 1.2m (1/2 Banjo X 3/8f)	1

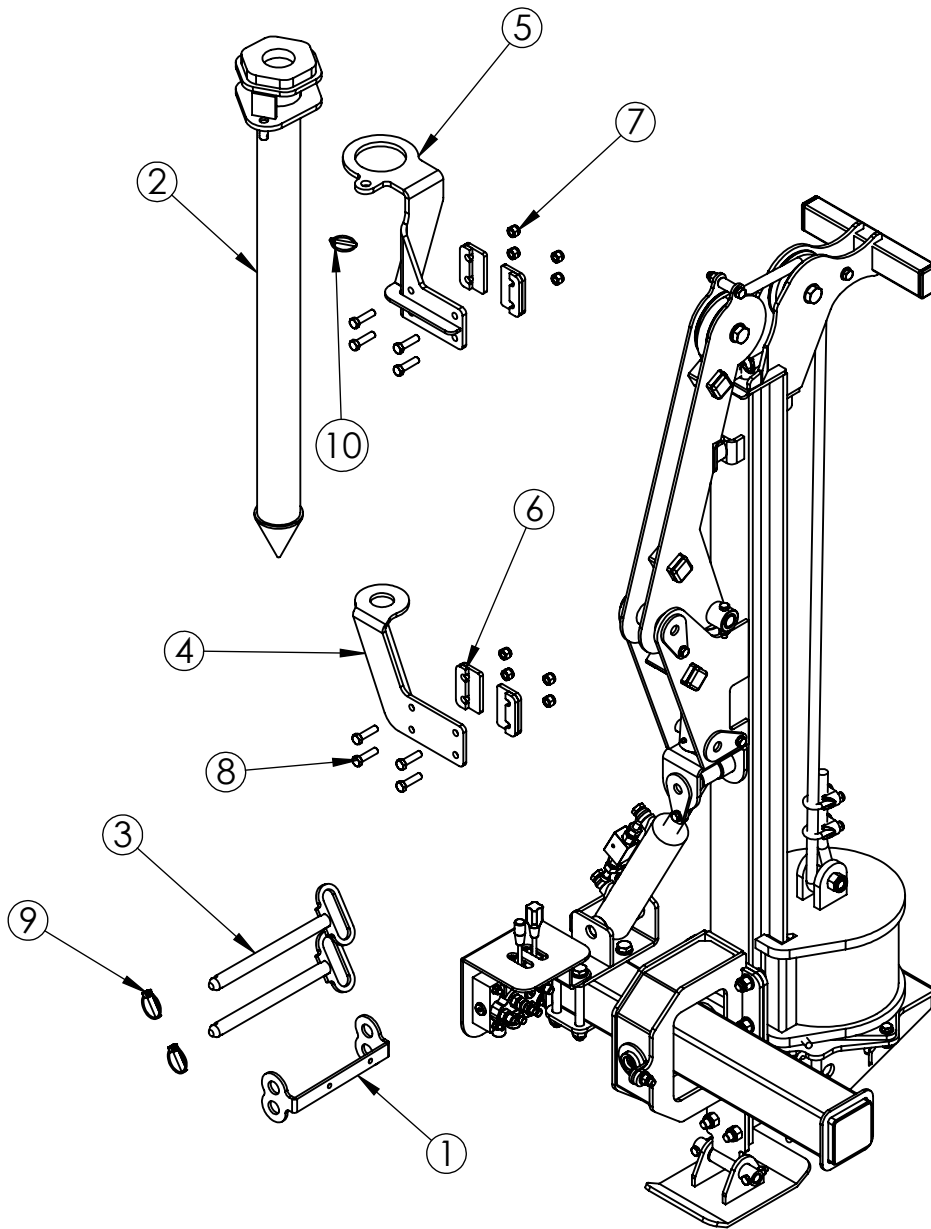

ROCK SPIKE KIT (55080)			
ITEM	PART No	DESCRIPTION	QTY
1	17884	PIN HOLDER BRACKET	1
2	55081	ROCK SPIKE	1
3	55082	ROCK SPIKE PIN	2
4	55083	LOWER BRACKET	1
5	55084	UPPER BRACKET	1
6	55085	BRACKET CLAMP	4
7	70012	M12 NYLOCK NUT	8
8	70026	M12 (8.8) x 45 SETSCREW	8
9	70033	LINCH PIN 7/16R	2
10	71748	LINCH PIN 6mm	1

10.0 Rock Spike Attachment

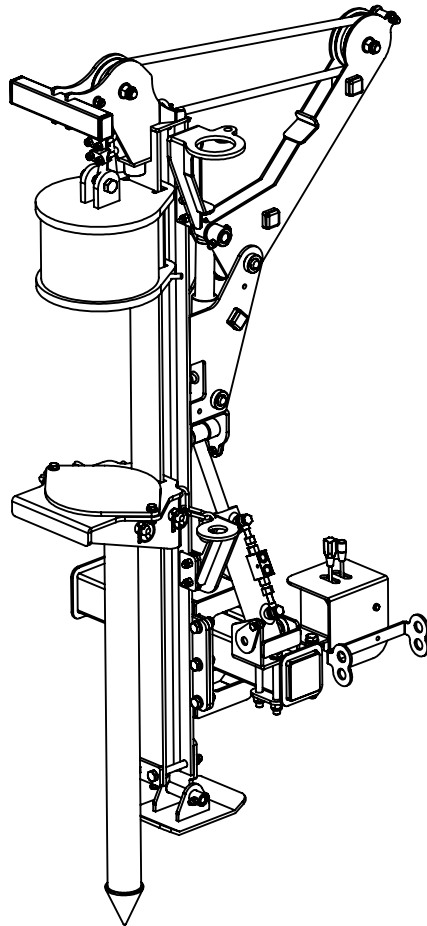

If the post hammer has been purchased with the rock spike attachment, then the attachment will have been delivered already attached, with the rock spike placed in its storage position on the side of the mast.

To remove the rock spike, crowd the post hammer, once fitted onto the excavator, so it is horizontal and close to the ground. Unscrew the ratchet handle on the lower storage bracket to release the rock spike and remove the lynch pin on the top storage bracket. Carefully slide the rock spike out so that it is resting on the ground.

Crowd the post hammer to the horizontal position and attach the post cap chains to the hammer hooks. Raise the hammer and attach the rock spike to the post cap with the two large lock pins. Once attached the post hammer can be placed where the hole is to be made. Once positioned, release the post cap from the hammer by removing the chains from the hooks and driving can commence.

After the operation is completed the rock spike is slide back into its storage brackets and fixed with the ratchet handle and lynch pin.



When handling the rock spike a manual handling assessment should be performed and assistance provided if required to avoid any injuries that could arise from lifting the rock spike. These can include strains and crush injuries.

11.0 Dismantling & disposal

When the machine has come to the end of its useful life it should be dismantled and disposed of in a safe and environmentally friendly manner.

It is very important not to leave the machine in a state that could be dangerous for people or the environment.

Waste oil must be collected and disposed of in accordance with local regulations.

Never pour used oil into drains or onto the floor.

Worn tyres and rubber parts must be disposed of by a licensed waste disposal company.



Protect the environment and ensure contaminated parts or waste oil are always disposed of or cleaned in safe and environmentally friendly manner.

12.0 Warranty Guidelines

The period of liability for warranty relating to our products is 12 months. The warranty period shall become effective upon installation of the machine with the end user. All wearing parts are excluded from the warranty.

Warranty will only be given if the machine has been used for the purpose indicated in this manual and the original specification of the machine has not been subject to unauthorised modification.

All warranty claims must be submitted the Browns via the dealership you purchase the machine from.

All warranty work must be carried out by authorised Browns dealers using original parts.

12.1 Modifications

Your Browns machine should not be modified or altered unless officially authorised by Browns. Any modifications will make the machine out of warranty and will make the declaration of conformity for the machine void.

However, if it is necessary to carry out modifications, then all modifications must be done by a competent person, based on a risk assessment. It is important to emphasise that the competent person who undertakes the modification assumes the role of the designer and manufacturer. All safety features must be retained in the modified machine.



Safety instructions must be reviewed after all modifications are carried out and revised where necessary.